

# Dellmeco®

## INSTRUCTION MANUAL

Air Operated Double Diaphragm Submersible Pumps  
PE conductive Plastic Series  
Ver. 10.1\_EN



**Models (with ATEX Certificate):**

**DMR 08/10 R..**

**DMR 10/25 R..**

Date of manufacture:

Serial no.



Management  
System  
ISO 9001:2015

www.tuv.com  
ID 9105038609

# DECLARATION OF CONFORMITY

**Directive 2006/42/EC, Annex 2A**

Company: **DELLMECO Krzysztof Ziemann**

Address: **Swierkowa 2  
83-330 Glinicz  
POLAND**

**declares under our sole responsibility, that the product:**

Product name: **Air Operated Double Diaphragm Submersible Pumps, PE cond.  
Plastic Series**

Models: **DMR - series**

Referred to in this declaration conforms with the:

**- Directive 2006/42/EC**

Date: **July 1<sup>st</sup> 2014**



**K. Ziemann  
Managing Director**

# Table of contents

<b>1. Introduction</b>	<b>4</b>
<b>2. For safe operation</b>	<b>4</b>
<b>3. Warnings and cautions</b>	<b>4</b>
<b>4. Operating caution</b>	<b>4</b>
<b>5. Names of parts and materials</b>	<b>6</b>
5.1. DMR 08/10 R., DMR 10/25 R.. – exploded view	6
<b>6. Assembly</b>	<b>8</b>
<b>7. Installation</b>	<b>8</b>
7.1. Installing the pump	8
7.2. Connecting the ground wire	11
<b>8. Connection</b>	<b>11</b>
8.1. Connecting fluid piping	11
8.2. Connecting air piping	12
<b>9. Operation</b>	<b>13</b>
9.1. Method of operation	13
9.2. Flow adjustment	13
9.3. Shutdown	14
<b>10. Method of cleaning</b>	<b>14</b>
<b>11. Daily check</b>	<b>15</b>
<b>12. Possible problems</b>	<b>15</b>
<b>13. Pump storage</b>	<b>17</b>
<b>14. Returning the product for servicing</b>	<b>17</b>
<b>14. Main body specification</b>	<b>19</b>
14.1. Main specification	19
14.2. Appearance and dimensions	19
14.3. Technical Data	20
14.4. Pump code	20
14.5. Performance curves	21
<b>15. Optional equipment</b>	<b>22</b>
15.1. Compressed air preparation set (Option code: AF1)	22
<b>16. Air valve execution material option and spare parts kit set (AVD)</b>	<b>22</b>
<b>17. ATEX Certificate</b>	<b>24</b>
<b>18. Limited warranty</b>	<b>25</b>

# 1. Introduction

This pump is a positive-displacement submersible pump that transfers fluids by means of diaphragms movement operated by compressed air. The casing in contact with the fluid is made of PE conductive (for ATEX) material. Other materials in contact with pumped liquid when the pump is submersed are: PTFE or AISI 316 (ball valves), AISI 304 (nuts, washers, housing bolts) and brass (quick-connectors).

# 2. For safe operation

This document contains information indispensable for maintaining safe and efficient operation of this product. Read this document carefully before using the pump, particularly the "Warnings and cautions". Get familiar with all operating procedures. This document must be kept handy for future reference.

# 3. Warnings and cautions

The meanings of warning and caution symbols are given below. Be sure to remember their meanings.



## WARNING:

ignoring the warning and operating the product in an improper manner can result in danger of serious bodily injury or death.



## CAUTION:

ignoring the warning and operating the product in an improper manner can result in danger of personal injury or property damage.



This symbol means a "DON'T", and will be followed by an explanation on what you must not do.



This symbol means a "DO", and will be followed by an explanation on what you must do in a specified situation.

# 4. Operating caution

Before using this product



## WARNING



To drive the pump you must use one of the following compressed gases (called in this document "compressed air"):

- Compressed air supplied from air compressor
- Nitrogen (N<sub>2</sub>) gas

Use of compressed air other than the above may cause air pollution, damage to the pump, or even an explosion.



The maximum permissible pressure for the compressed air, and the fluid pumped by one of its pumps is 7 bar g. Should the above applicable maximum permissible pressure be exceeded, the following results may follow: damage to the casing, or even a severe, possibly fatal accident.



In case a diaphragm gets damaged, fluid will gush out together with air through the exhaust port. Provide protective measures in consideration of possible leakage of fluid. When using the pump with suction/discharge hoses, tank etc. for pumping, make sure to use a model with appropriate corrosion resistance for the fluid to be pumped.



## WARNING

- ! When installing this product without submersion, be sure to connect a ground wire from the specified grounding point. Otherwise friction between parts and abrasion caused by the flow of some fluids inside the casing may generate static electricity. Depending on the type of fluid being pumped and the installation environment (such as gases in the air and type of surrounding mixtures), static electricity could cause fire or electric shock.
- ! Some fluid may remain inside the pump and inside the connected piping after shutting down the pump, or if the pump is left unused for a prolonged period.  
Therefore, be sure to purge the system of fluid and clean the pump before prolonged disuse.  
The fluid remaining in the connected piping as well as the pump itself may expand because of freezing or heat which may cause damage to the pump or/and piping and lead to leakage of the fluid.
- ∅ Use only genuine DELLMECO parts when replacing component parts of this product.
- ! Torque of all tightening parts must be checked before running the pump. Designated torques are mentioned in maintenance manual.
- ! In case of pumping a hazardous fluid (hot, flammable, strong acid, etc.) with this pump, protective measures (install a pit, a protection box, sensors, etc.) must be provided in consideration of possible leakage of fluid. Warning signs must be displayed at necessary places. Leakage of fluid may cause fire or accident.
- ! Before using this pump, get fully familiar with the precautions regarding the fluid to be pumped, and verify the corrosion resistance of the parts that will come into contact with the fluid. NEVER use the pump with any fluid against which it does not have sufficient corrosion resistance or with a fluid that poses a risk of explosion. If you are unable to verify the corrosion resistance, contact your dealer. Using this product with any fluid against which the parts in contact with the fluid do not have sufficient corrosion resistance may result in damaging the product or leakage of fluid.



## CAUTION

- ! The running pump may generate loud operating noise. Its level will vary depending upon the conditions of use (fluid pumped, supply air pressure and discharge pressure)
- ! To drive this product, supply air with minimum moisture content and without any oil and/or dirt.
- ! If a diaphragm of this pump is damaged, supply air may mix with the fluid or the fluid may flow into the central housing. **DO NOT OPERATE THE PUMP** if air supply is inadequate or contaminated.
- ∅ While operating this product, do NOT put your hand on the inlet port.

## 5. Names of parts and materials

### 5.1. DMR 08/10 R., DMR 10/25 R.. – exploded view

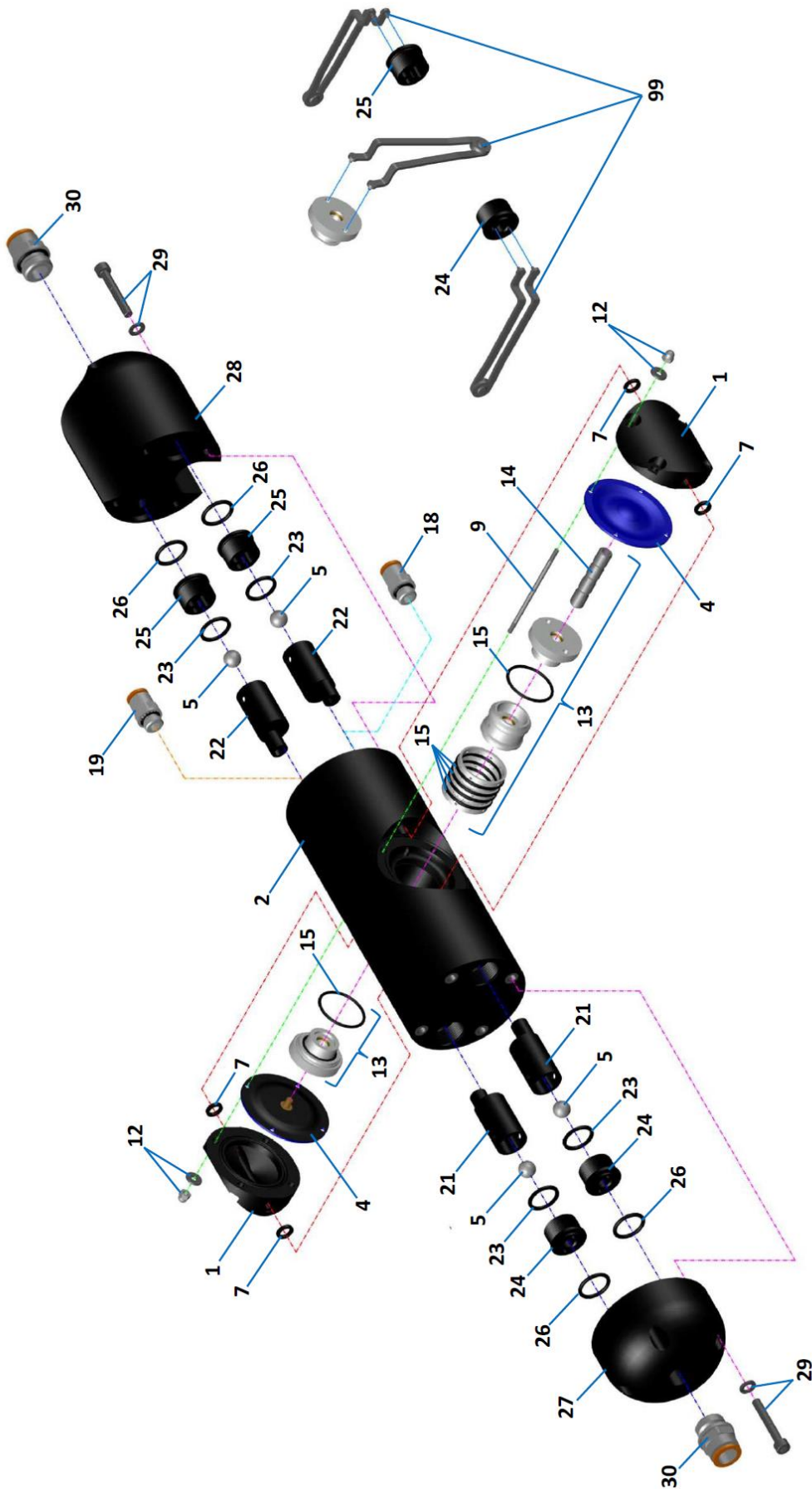

**Spare parts list for PE cond. Plastic Series Pumps: DM 08/10 R., DMR 10/25 R..**

				Pump size and material execution (R-PE conductive)	
Item	Part name	Quantity	Material	DMR 08/10 R..	DMR 10/25 R..
1.	Pump housing	2	PE conductive	10 08 01 21	10 10 01 21
2.*	Central housing	1	PE conductive	10 08 10 21	10 10 10 21
4.	Diaphragm	2	EPDM		1 10 50 08
			NBR		1 10 50 10
			TFM(PTFE)	1 08 50 05	1 10 50 05
			TFM(PTFE)-PFA	1 08 50 00	1 10 50 00
5.	Ball valves	4	AISI 316	1 08 60 52	1 10 60 52
			PTFE	1 08 60 23	1 10 60 23
7.	Side housing seal	4	PTFE conductive	10 08 70 24	10 10 70 24
9.	Housing bolt	4	AISI 304	10 08 042 50	10 10 042 50
12.	Nut with washer set	8	AISI 304	10 08 045 50	10 10 045 50
13.*	Air valve, complete (threaded)	1	PET-FKM	1 08 020 32	
14.1)	Air valve/diaphragm shaft	1	AISI 304	1 08 24 50	
15.1)	Air valve O-ring, external	6	FKM	1 08 080 09	
18.	Air supply quick coupling	1	Diverse	10 08 46 00	10 08 46 00
19.	Air exhaust quick coupling	1	Diverse	10 08 146 00	10 08 146 00
21.	Suction valve seat	2	PE conductive	10 08 054 21	10 08 054 21
22.	Discharge valve seat	2	PE conductive	10 08 154 21	10 08 154 21
23.	Suction/discharge plug seal	4	PTFE conductive	10 08 78 24	10 10 78 24
24.	Suction valve plug	2	PTFE conductive	10 08 59 21	10 10 59 21
25.	Discharge valve plug	2	PTFE conductive	10 08 55 21	10 10 55 21
26.	Side adapter O-ring	4	FKM	10 08 778 09	10 10 778 09
27.	Suction side adapter	1	PE conductive	10 08 246 21	10 10 246 21
28.	Discharge side adapter	1	PE conductive	10 08 346 21	10 10 346 21
29.	Hexagonal screw with washer, cpl.	8	AISI 304	10 08 242 50	10 10 242 50
30.	Suction/discharge quick coupling	2	Diverse	10 08 11 00	10 10 11 00
35.	Central housing complete	1	Diverse	10 08 11 00	10 10 11 00
99.**	Universal key	1	Structural steel		1 10 58 00

\* - parts included in Item 35 „Central housing complete“;

\*\* - available on request (not delivered with the pump nor with spare part kit sets).

1) - included in Item 13 „Air valve, complete“, but also can be ordered separately.

**List of parts for spare part kits SET 1 and SET 2 in Plastic Series Pumps DMR 08/10 R.. and DMR 10/25 R..**

Spare part kit set type	Item	Quantity	Part description	Pump size						
				DMR 08/10			DMR 10/25			
				Material execution <sup>A)</sup>						
				RTT	RTS	RFT	RET	RNT	RTT (RTS)	RFS
				Part number						
SET 1 (wet side)	4.	2	Diaphragm	1 08 50 05		1 08 50 00	1 10 50 08	1 10 50 10	1 10 50 05	
	5.	4	Valve ball	1 08 60 23	1 08 60 52	1 08 60 23	1 10 60 23		1 10 60 23 (1 10 60 52)	1 10 60 52
	7.	4	Side housing seal	10 08 70 24			10 10 70 24			
	23.	2	Suction/discharge plug seal	10 08 78 24			10 10 78 24			
	26.	2	Side adapter O-ring	10 08 778 09			10 10 778 09			
	13.	1	Air valve PET/FKM, threaded	1 08 020 32						
	21.	2	Suction valve seat	10 08 054 21			10 10 054 21			
	22.	2	Discharge valve seat	10 08 154 21			10 10 154 21			
	24.	2	Suction valve plug	10 08 59 21			10 10 59 21			
	25.	2	Discharge valve plug	10 08 55 21			10 10 55 21			

A) - typical pump material executions (other material executions may require different spare parts).

## 6. Assembly



### CAUTION



When installing accessories prevent any foreign matter from getting into the product.  
Otherwise malfunction of the air-valve may follow.

## 7. Installation

### 7.1. Installing the pump

1) Decide where the pump is to be installed and secure a site.

Note:

- The suction lift should be kept as short as possible.
- Sufficient space around the pump for maintenance must be provided.



## SUBMERGED OPERATION

All pumps may operate in full submersion. Construction materials must be compatible with surrounding liquid and the air exhaust must be placed above the liquid level.

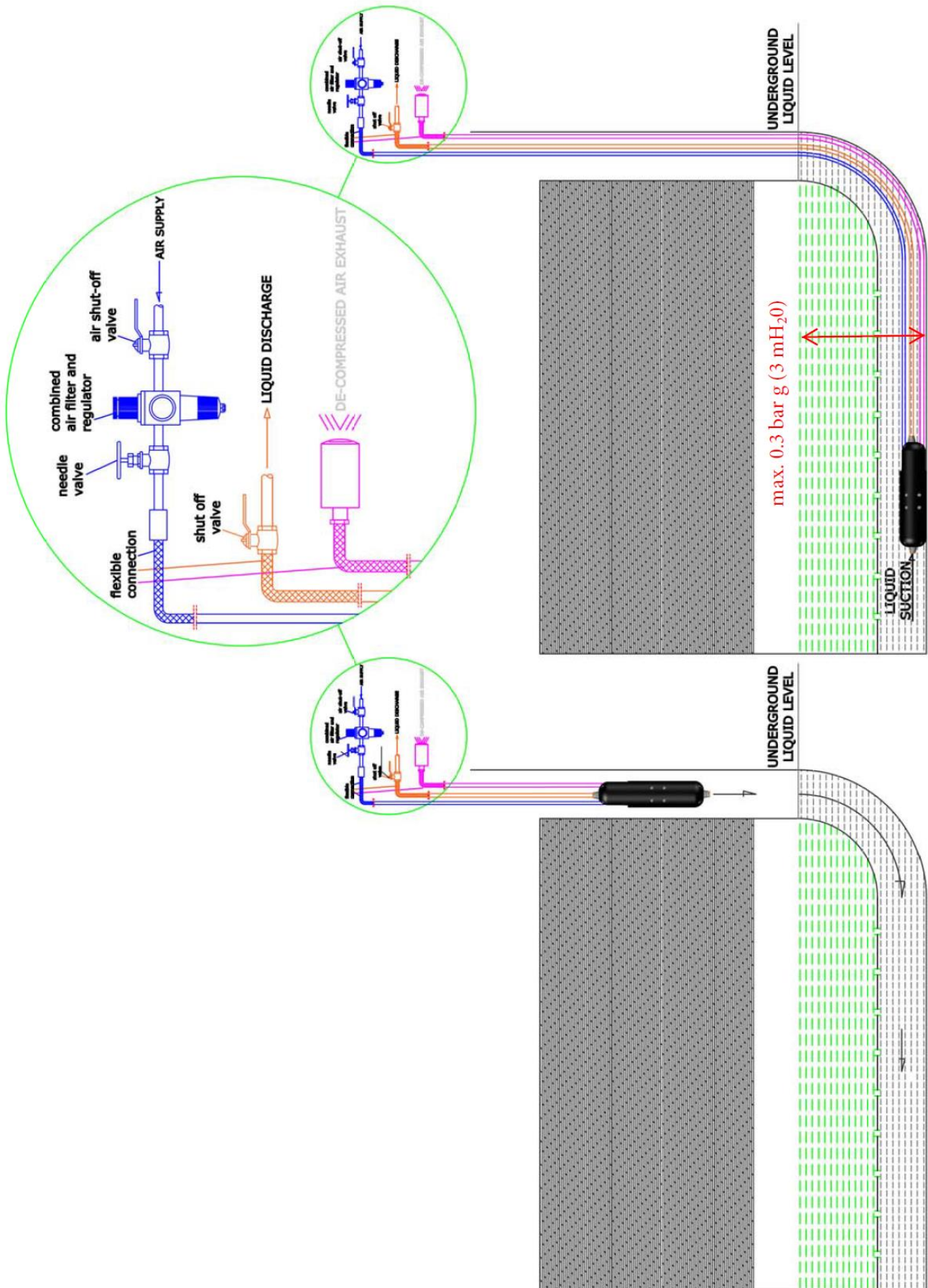



## CAUTION



When using the pump in submerged position, follow the steps below:

- Verify the corrosion resistance of each component of the pump. DO NOT expose the pump to any fluid for which it does not have proper corrosion resistance.
- Exhaust should be directed outside, not into the fluid in which the pump is submerged.



The running pump may generate noise. Its level will depend upon conditions of use (kind of fluid being pumped, supply air pressure and discharge pressure).



## WARNING



The end of the hose must be equipped with a pit, a protection box, etc. at the end of the hose in case the diaphragm gets damaged and a leakage of the fluid follows.



Pump exhaust should be directed to a safe place, away from people, animals and food.

Size	DMR 08/10	DMR 10/25
<b>Max number of strokes/min. at nominal performance</b>	500	430



## CAUTION



Before putting the pump into operation as well as after some hours of pumping, all housing bolts [9] have to be fixed according to the torque data of the following schedule, as the elements of construction "settle". All hexagonal screws [29] have to be fixed, too. Fixing all these parts is necessary as well after longer periods of stoppage, at extreme temperature variations, after transport and dismantling the pump.

Size	DMR 08/10 R..	DMR 10/25 R..
<b>Torque values for housing bolts (Nm): PE conductive pumps</b>	2	4

## 7.2. Connecting the ground wire

- a) When installing the conductive pump NOT IN submersible position, be sure to connect the ground wire at the specified grounding point.
- b) Ground wires should be connected to peripheral equipment and piping as well.
- c) Use 2.0 mm<sup>2</sup> minimum ground wire.



## WARNING



Ground wires must be connected to the piping and any other peripheral equipment. When operating the pump make sure it is properly grounded. Otherwise friction between the parts and abrasion caused by some fluids flowing inside the casing may generate static electricity. In addition it may cause fire or electric shock, depending on the type of fluid being pumped and the installation environment (such as gases in the air or the surrounding mixtures).

## 8. Connection

### 8.1. Connecting fluid piping

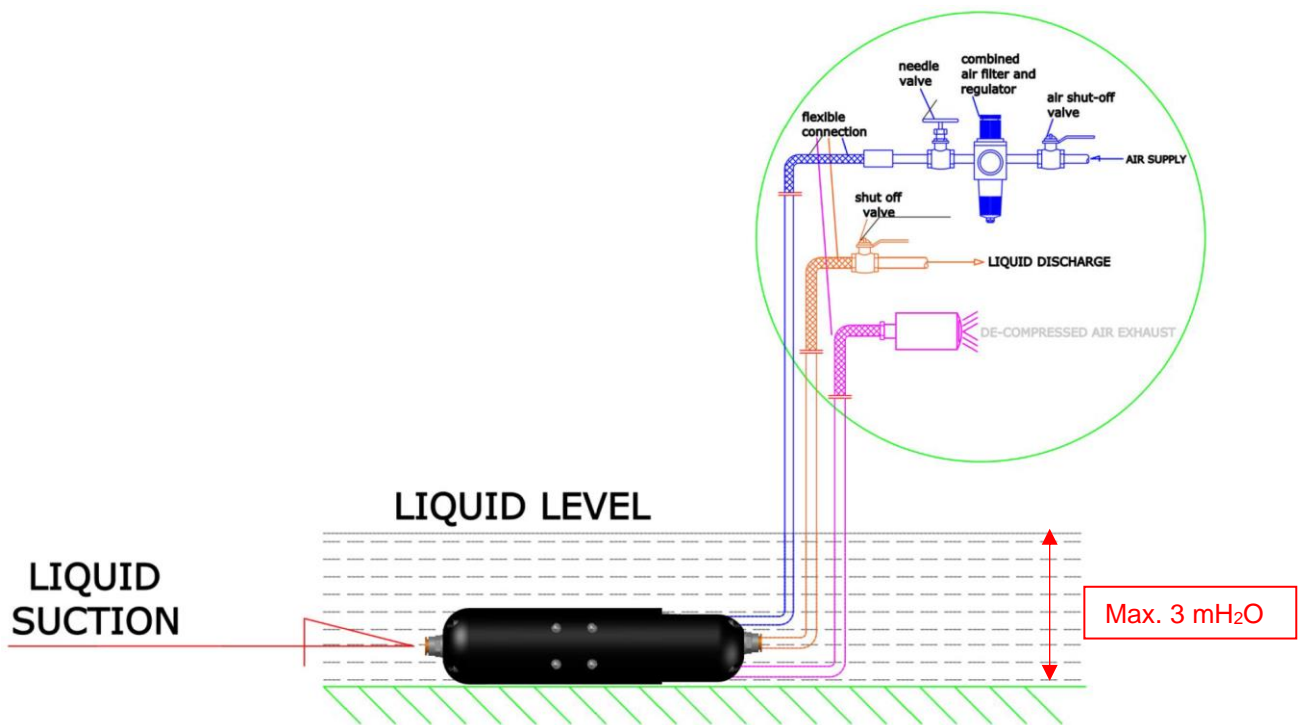

- 1) Connect a flow valve and a drain valve to the fluid discharge port of the pump.
- 2) Connect a valve for maintenance to the fluid suction intake port of the pump.
- 3) Connect a hose to the valve on the suction-port side and the valve of the discharge-port side of the pump.
- 4) Connect a hose on the suction-side intake (If necessary) and the discharge-port side to the respective vessels.



## CAUTION

- ! A hose must be flexible to absorb pump vibration. The hose must be grounded.
- ! There must be NO external force on any connection part of the pump. Be especially careful not to have the pump support part of the weight of the hose and the piping.
- ! Use a sturdy hose that will not collapse under the strong suction of the pump. The hose must be of more than sufficient pressure rating.
- ! Use a hose of a diameter the same as or larger than the pump's ports. If the diameter of a hose is smaller, it will affect the pump's performance or cause its malfunction.
- ! Keep a vessel below the relief valve to catch any drain off.
- ! The product has been inspected using clean water at 8 bar discharge pressure.

### 8.2. Connecting air piping



## WARNING

- ! Before starting work, make sure that the air compressor is shut off.

- 1) Connect an air valve, air filter, regulator to a hose connected to the compressor. Install items near the pump.
- 2) Connect the hose from the peripheral equipment to the air valve of the pump's supply port.

#### Note:

The diameter of the piping should be the same as the diameter of the pump supply port in order to supply sufficient air. Peripheral equipment with sufficient airflow should be chosen to meet the requirement of the pump air consumption. It must be installed nearest the pump unit, even using dry air. Usage and stability of air pressure must be considered.

## 9. Operation

### 9.1. Method of operation



#### CAUTION

- ! Before starting the pump, check that all piping is properly connected.
- ! Before starting the pump, check that **all the bolts are securely tightened**.
- ! Check that the regulator and the drain valve on the discharge side are closed and that the valve on the suction side is opened.

- 1) Start the air compressor.
- 2) Open the air valve. Using a regulator adjust the supply air pressure to within the permissible range.
- 3) Open the flow valve on the discharge side.
- 4) First, check that fluid is flowing inside the piping and is being pumped to the discharge side, and then fully open the air valve.



#### CAUTION

- ∅ Do NOT open the air valve suddenly.

### 9.2. Flow adjustment

Adjust the flow valve on the discharge side, or adjust the supply air pressure.



#### CAUTION

- ! The supply air pressure may initially rise during closing the flow valve. Make sure that the pressure is kept within the normal operating range.
- ! The permissible suction flow speed can vary depending upon the viscosity and specific gravity of the fluid, the suction stroke and other factors. However in case of a rapid growth of the pump speed (flow speed of fluid), cavitation will occur. This will reduce pump performance and may cause a malfunction. In order to prevent cavitation, adjust the supply air pressure and the flow.
- ! If fluid is not discharged after you start the pump, or if you hear an abnormal noise or notice any irregularity, shut down the pump immediately.

### 9.3. Shutdown

Close the air valve of the pump and shut off the supply air. DO NOT stop the pump by closing the discharge valve while the compressed air is still supplied to the pump.



#### CAUTION

- ! When the pump is shut down while pumping slurry, particulate matter contained in the slurry will be deposited and get stuck inside the out chamber. Therefore after finishing work the pump must be purged of the remaining fluid. Otherwise when starting the pump again, the diaphragm may get damaged and the diaphragm shaft rod may bend.



#### CAUTION

- ! Keep a vessel below the relief valve for any drain off.
- ! Be careful! - Fluid under pressure will gush out the moment you open the valve.
- ! If the pump is unused for a prolonged period, purge and clean it.

## 10. Method of cleaning



#### WARNING

- ! Make sure that compressed air is not supplied to the pump BEFORE you start cleaning the pump.
- ! Make sure that the pump is not pressurized BEFORE you start cleaning the pump.

- 1) Remove the hose from the suction side of the pump.
- 2) Close the flow valve on the discharge side and open the drain valve. Then start air pressure for a while to discharge possibly much fluid remaining inside the pump.
- 3) Remove the hose from the discharge side, and attach different hoses to the suction side and the discharge side for cleaning.
- 4) Be ready with a vessel with cleaning solution, the kind appropriate for the type of fluid pumped. Next connect the suction-side and the discharge-side hoses of the pump.
- 5) Start the pump air pressure slowly, and let the cleaning solution circulate for sufficient cleaning.
- 6) Flush with clean water.
- 7) Remove the hose from the suction side of the pump, run the pump for a while to purge the pump of remaining fluid as much as possible.



## CAUTION



Be extremely careful when removing piping - the fluid will gush out.



After cleaning with clean water, turn the pump upside-down to let the water flow out.

## 11. Daily check

Before starting pump operation, conduct the following check procedures every day. In case there appears any irregularity, do NOT start running the pump until the cause of the irregularity has been determined and corrective measures have been taken.

- a) Make sure that there is no leakage of fluid from any connection part or the pump.
- b) Make sure that there are no cracks in the pump casing or piping.
- c) Check the tightness of every bolt of the pump.
- d) Make sure that the connection parts of the piping and peripheral equipment are not loose.
- e) Be sure that any pump parts to be replaced at regular intervals have been changed.

## 12. Possible problems

### 12.1. Pump does not run

Cause	Action to take
The exhaust port (muffler) of pump is clogged with sludge.	Check and clean the exhaust port and replace muffler.
Air is not supplied.	Start the compressor, and open the air valve and air regulator.
The supply air pressure is low.	Check the compressor and the configuration of air piping.
Air leaks from connection parts.	Check the connection parts and tightness of bolts.
The flow valve on the discharge side is not open.	Open the flow valve on the discharge side.
The fluid piping is clogged with sludge.	Check and clean the fluid piping.
The pump is clogged with sludge.	Disassemble the casing, check and clean.

### 12.2. Pump runs, but fluid does not come out

Cause	Action to take
The suction lift or discharge head is long.	Confirm the piping configuration and shorten the length.
The discharge-side fluid piping (including the strainer) is clogged with sludge.	Check and clean the fluid piping.
The valve on the suction side is not open.	Open the valve on the suction side.
The pump is clogged with sludge.	Disassemble the casing, check and clean.
The balls and valve seats are worn out or damaged.	Disassemble the pump, check and replace parts.

### 12.3. Flow (discharge volume) decreased

Cause	Action to take
The supply air pressure is low.	Check the compressor and configuration of air piping.
Air piping or peripheral equipment is clogged with sludge.	Check and clean the air piping.
The discharge-side flow valve opens differently.	Adjust the discharge-side flow valve.
Air is taken in together with fluid.	Replenish fluid and check the configuration of the suction-side piping.
Cavitation occur.	Adjust the supply air pressure and discharge pressure, and shorten the suction lift.
Chattering occurs.	Adjust the supply air pressure and discharge pressure. Reduce inlet flow valve to adjusting liquid pressure and volume.
The fluid piping (including the strainer) is clogged with sludge.	Check and clean the fluid piping and strainer.
The exhaust port (muffler) of the pump is clogged with sludge.	Check and clean the exhaust port and muffler.
The pump is clogged with sludge.	Disassemble the casing, check and clean.

### 12.4. Liquid leakage from exhaust port (silencer)

Cause	Action to take
Damaged diaphragms.	Replace the diaphragms.

### 12.5. High air consumption during operation

Cause	Action to take
The air valve O-rings and sleeves are worn out.	Disassemble the air-valve, check and clean. Replace parts as necessary.



### 12.6. Irregular noise

Cause	Action to take
The supply air pressure too high.	Adjust the supply air pressure.
The pump is clogged with sludge with particles of larger than the permissible diameter.	Disassemble the casing, check and clean.

### 12.7. Irregular vibration

Cause	Action to take
The supply air pressure too high.	Adjust the supply air pressure.
The sleeves are worn out.	Disassemble the air-valve, check and clean. Replace parts as necessary.
Connection parts and pump mounting are loose.	Check each connection part and tighten the bolts.

*If any of the above mentioned causes do not apply to your problem, contact your dealer or our office.*

## 13. Pump storage

Usually each DELLMECO pump is delivered packaged, but after unpacking it is ready for operation. If the pump unit is not to be installed right after delivery, proper storage conditions have to be ensured for a later trouble-free operating. The pump has to be protected from wetness, coldness, heat, dirtying, UV-radiation (especially PE Pumps) and mechanical influences.

Recommended storage conditions are as follows:

- Steady ventilated storage room, free of dust and vibration
- Ambient temperature between 15°C (59°F) and 25°C (77°F)
- Relative humidity below 65%
- Protection against direct thermal influences (sun, heating).

## 14. Returning the product for servicing

If you want to return the product for servicing, copy the **Trouble-Reporting Datasheet** (page 18), fill it out giving the details of the problem and conditions of operation, scan it and send via e-mail to your dealer or our regional office. When you get an acceptance from your dealer or regional office:

- 1) Clean the pump.
- 2) Return the product in the same package as when it was first shipped from the factory.

## Trouble-Reporting Datasheet

Your information will be most helpful in our efforts to improve our service as well as checking into causes of troubles and irregularities. We kindly request you therefore to fill out the following datasheet carefully, scan it and e-mail it to your dealer or our regional office. Thank you.

<b>Company</b>	<b>Name of person in charge</b>
<b>Address</b>	<b>Department</b>
	<b>Telephone</b>
	<b>E-mail address</b>
<b>MODEL</b>	<b>Year of manufacturing</b>
<b>Period of use</b>	<b>Serial No.</b>
<b>Operating conditions</b> *Indoor                      * Outdoor	<b>Date of Purchase</b>
<b>Frequency of operation</b> * Continuous              * Intermittent  _____ Hours/day/week/month	<b>Name of Dealer</b> _____  <b>Type of fluid pumped</b>  _____
<b>Operating air pressure</b> _____ bar <b>Discharge pressure</b> _____ bar <b>Discharge volume</b> _____ l/min. <b>Suction side</b> _____ m <b>Suction side diameter</b> _____ m <b>Discharge side</b> _____ m	<b>Specific gravity</b> _____ <b>Viscosity</b> _____ cP <b>Fluid temperature</b> _____ *C/*F <b>Slurry:</b> *YES <b>Density</b> _____ wt% <b>Particulate diameter</b> _____ mm *NO
<b>Problem</b>	
<b>Draw a summary drawing of application, including size, length of piping, and component parts (if more space for a drawing/sketch is required, please do it on the reverse side of this document, or send e-mail it as a separate file in one of the following formats: png, jpg, pdf)</b>	



## WARNING



It is the end-user responsibility to thoroughly wash and clean the pump to prevent any damages caused by accidental liquid leaks.



## CAUTION



Be sure to maintain the transport safety by preventing any liquid leaks from the pump.

## 14. Main body specification

### 14.1. Main specification



## CAUTION



Due to constant improvements and/or modifications to our products, the dimensions and detailed technical specifications may be changed without prior information. Any claims concerning these changes shall not be considered. Please contact your dealer or our regional office for details.

### 14.2. Appearance and dimensions

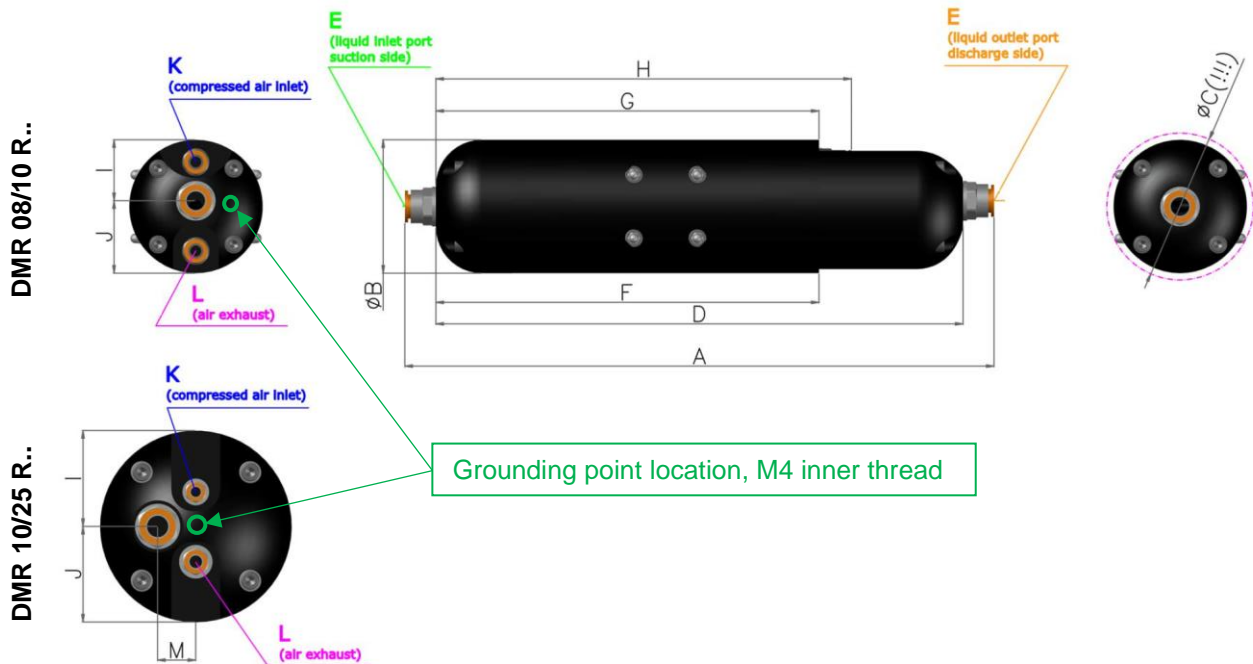

Pump size	A	øB	øC	D	øE	F	G	H	I	J	øK	øL	M
DMR 08/10 R..	387	88	96	245	14	271	251	268	40	47	8	10	-
DMR 10/25 R..	473	125	135	426	16	356	336	353	62	62	8	10	25

### 14.3. Technical Data

Pump size	DMR 08/10	DMR 10/25
Max. capacity [l/min.]	10	25
Max. pressure [bar g]	7	
Nominal port size (hose, O.D.) [mm]	Ø14	Ø16
Air connection (hose, O.D.) [mm]	Ø8	
Max. suction lift wet* [MWC]	7.0	
Max. size of solids [mm]	2.0	3.0
Temperature limits – PE c. [°C]	70	
Weight – PE c. [kg]	2	4
Material of pump wetted parts	PE conductive	
Diaphragm material options	TFM, TFM-PFA	EPDM, NBR, TFM, TFM-PFA
Valve balls material options	AISI 316, PTFE	
O-rings material options	FKM	

\* – real wet suction lift values can be smaller from the stated maximum values, due to: diaphragms material, liquid properties (specific gravity, dynamic viscosity), suction hose inside diameter, etc.

### 14.4. Pump code

DMR 08/10 RTS-AF1	AF1 - Optional equipment:
<p><b>DM</b> – DELLMECO Pump</p> <p><b>08</b> – ½“ BSSPP port dimension</p> <p><b>10</b> – max capacity l/min at 8 bar g air supply pressure (free flow conditions)</p>	<p><b>AF1</b> - Air filter, regulator, valve, nipple, connector</p>
<p><b>R – Housing material:</b></p> <p>R – PE conductive (ATEX)</p>	
<p><b>T – Diaphragm material:</b></p> <p>E – EPDM</p> <p>F – TFM/PTFE/PFA</p> <p>N – NBR</p> <p>T – TFM/PTFE</p>	
<p><b>S - Material and kind of valve:</b></p> <p>S - AISI 316, ball valve</p> <p>T - PTFE, ball valve</p>	

14.5. Performance curves

**DMR 08/10**

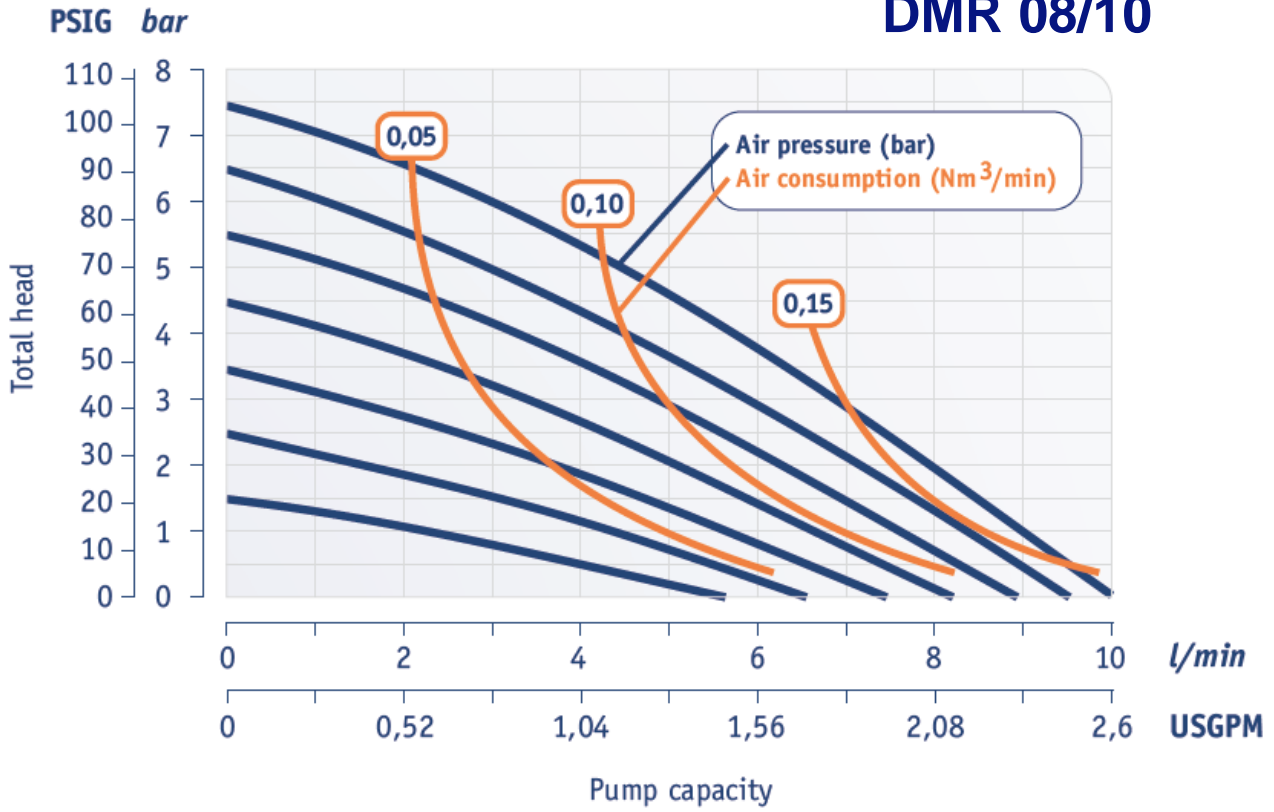

**DMR 10/25**

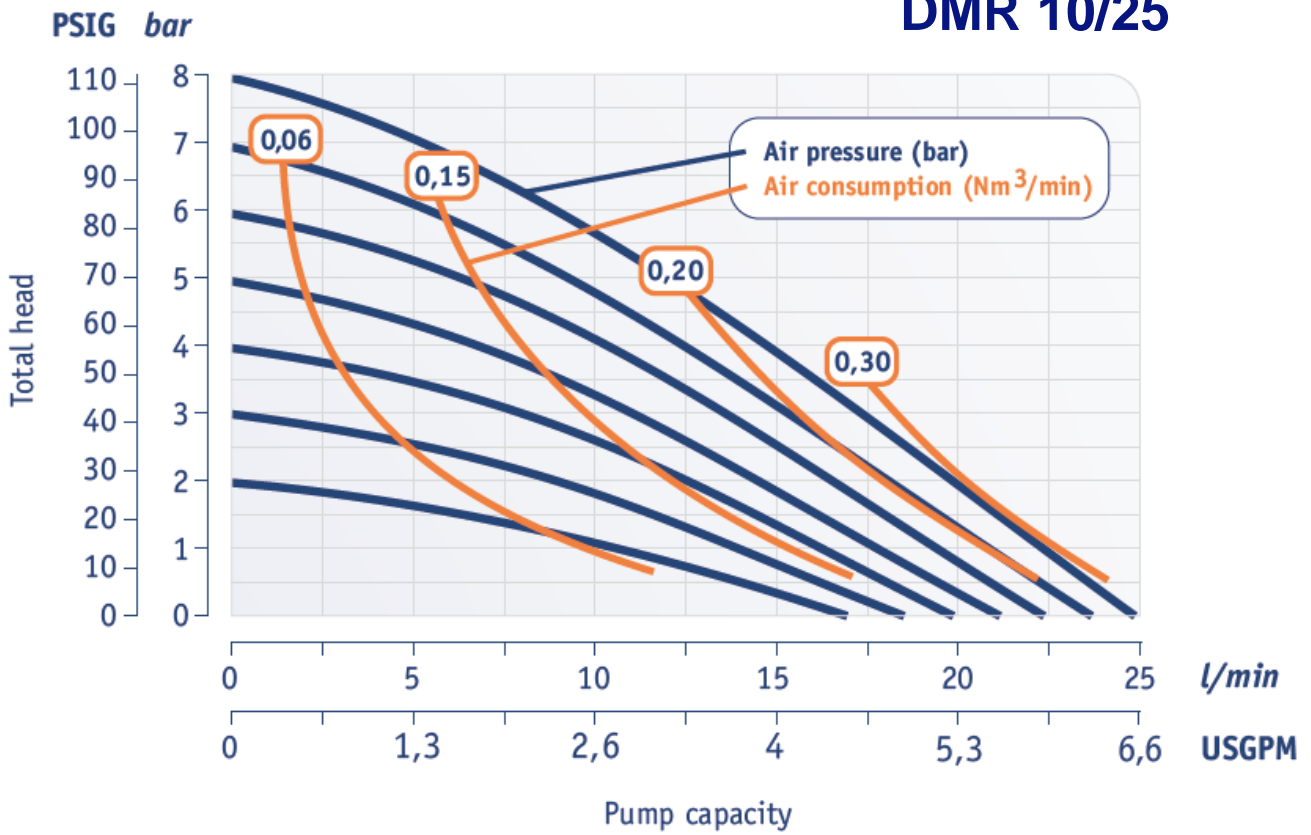

## 15. Optional equipment

### 15.1. Compressed air preparation set (Option code: AF1)

Compressed air delivered to the pump has to be dry, free from oil and humid (air valve installed inside the central housing do not require lubrication – it works completely oil-free). If you are not sure about the compressed air purity level or the available air is not of good quality, you can install the air preparation set, which consists of:

- Air filter-regulator unit with valve,
- Pressure gauge,
- Hose connectors (quick couplings).

Depending on the size of the pump, there are two available AF Options:

- AF1 – for the pumps from DMR 08/10 up to DMR 10/25 size;

AF Option is also available in explosion-proof execution (AF1X, with ATEX Certificate) – for more information please contact our Sales Department at [office@dellmeeco.com](mailto:office@dellmeeco.com).

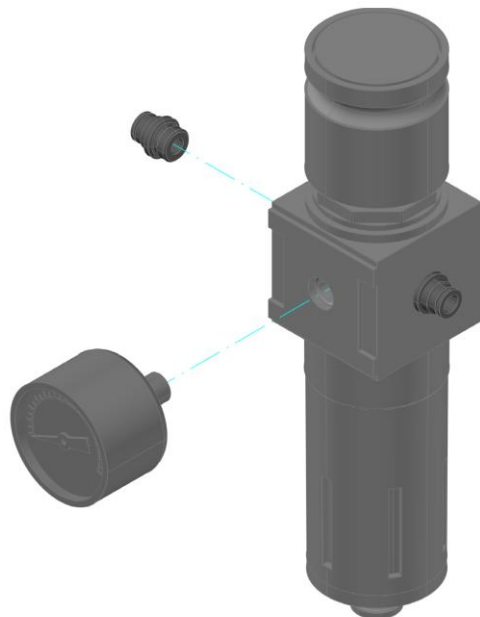

## 16. Air valve execution material option and spare parts kit set (AVD)

DELLMECO Submersible Series Pumps from DMR 08/10 up to DMR 10/25 size are equipped with PET/NFKM air valve (standard execution), where the main parts – cylinder, piston, side covers – are made from PET, while the external O-rings (Item No. 15 in the spare parts list) are made from FKM material.

The general design of DELLMECO Plastic Submersible Series Pumps is quite simple. However, special tool is required in order to assemble/disassemble air valve from the pump. This special tool presented below is not delivered with pump and has to be ordered separately:

- 1) Universal adjustable key [100], with 2 pins (diameter of each pin is ca 4 mm):



Appearance of an air valve for DELLMECO Plastic Submersible Series Pumps is presented below:

**A. Air valve “08” size (part no.: 1 08 020 32, PET/FKM), applicable for DMR 08/10 ... and DMR 10/25... Pump models:**

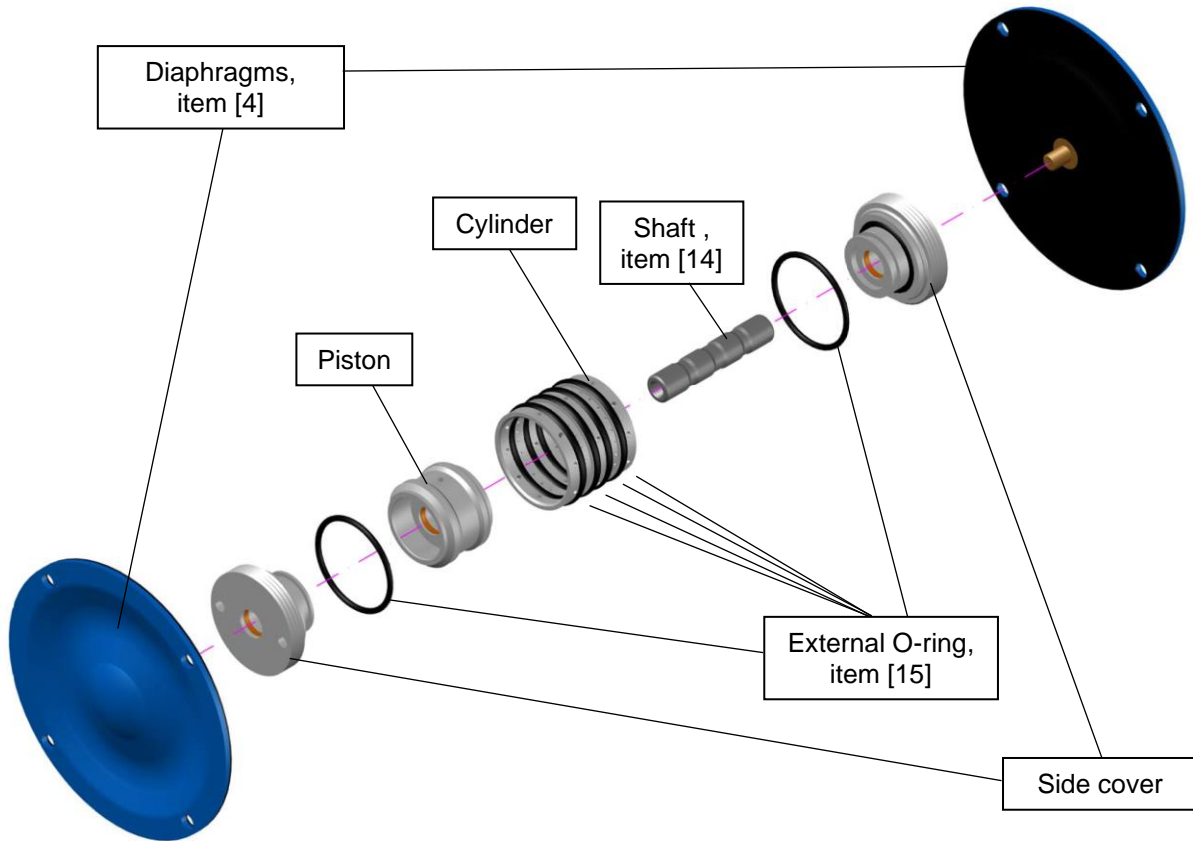

The distinguishing feature of the smallest “08” air valve is that the main shaft (made from AISI 304 material) is a common element for both diaphragms and air valve unit. Each diaphragm (“08” and “10” sizes only!) has external thread that allows to assemble them directly on the main shaft.

For the Plastic Series Pumps the following combinations of the main parts/O-ring execution materials can be offered:

- 1) AISI 316L/FKM (main parts – cylinder, piston, side covers – made from AISI 316L, the external O-rings are made from FKM) – for the sizes from DMR 08/10 up to DMR 10/25 (air valve: “08” size).
- 2) Brass/FKM (main parts – cylinder, piston, side covers – made from brass, the external O-rings are made from EPDM) – for the sizes from DMR 08/10 up to DMR 10/25 (air valve: “08” size).
- 3) Brass/FKM (main parts – cylinder, piston, side covers – made from brass, the external O-rings are made from FKM) – for the sizes from DMR 08/10 up to DMR 10/25 (air valve: “08” size).

Not always an air valve unit has to be replaced completely – in some cases, air valve may require replacement of all internal slides and O-rings only (these parts are getting wear during normal operation of the pump) – this is why we also offer DELLMECO Air Valve Spare Part Kit Set (**AVD”xx”**, where “XX” stands for the size of the air valve). Depending on the air valve size and material execution (also for the slides and O-rings), the following set is available:

- AVD01F (“08” size air valve with FKM O-rings).

## 17. ATEX Certificate

DELLMECO Plastic Series Pumps manufactured from conductive PE can be adapted for installation and use in potentially explosive atmospheres. This feature ensures the pump can safely transfer inflammable solvents, alcohols and other volatile liquids without the danger of static electricity build-up (through grounding of non-metallic pumps). An appropriate combination of conductive materials makes DELLMECO Plastic Series Pumps suitable to work in explosive gas and dust environments without the risk of spark formation.

**Plastic Submersible Pump dedicated for ATEX  
(PE cond. or PTFE cond. material)**



Standard ATEX execution can be used for the following conditions:

**CE  $\text{Ex}$  2GD IIA/IIB T1÷T5**

In order to obtain the additional information, please contact our customer support at: [office@dellmecco.com](mailto:office@dellmecco.com) .



## 18. Limited warranty

This product is shipped to customers only after meeting strict inspection standards. If an abnormality occurs during normal operation in accordance with the operating instructions and other operating cautions within the warranty period (24 months after date of purchase) that can be attributed to a manufacturing defect, the defective parts of this product will be serviced or the product will be replaced free of charge. However, this warranty will NOT cover compensation for incidental damage or any malfunction listed below.

### 1. Warranty period

This warranty is valid for 24 months after the date of purchase.

### 2. Warranty

If, during the warranty period, any of the material of the genuine parts of this product or the workmanship of this product is found defective, and is so verified by our company, the servicing cost will be fully covered by our company.

### 3. Exclusion

Even during the warranty period, this warranty DOES NOT cover the following:

- 1) Malfunction caused by the use of parts other than manufacturer-specified genuine parts.
- 2) Malfunction caused by misuse or operating errors, or lack of storage or maintenance care.
- 3) Malfunction caused by the use of a fluid that may cause corrosion, inflation or dissolution of the component parts of the product.
- 4) Irregularity caused by a repair made by other than our firm, our regional office, dealer or authorized service personnel.
- 5) Malfunction caused by a modification of the product by other than authorized service personnel.
- 6) Wear and tear of parts that must be regularly replaced in the course of normal operation, such as diaphragms, valve seats, balls, air motor sleeve valves and O-rings.
- 7) Malfunction and/or damage due to transportation, moving or droppage of the product after purchase.
- 8) Malfunction and/or damage due to fire, earthquake, flood or other force majeure.
- 9) Malfunction caused by the use of compressed air that contains impurities, air with oil or excessive moisture, or use of gases or fluids other than the specified compressed air.
- 10) Malfunction caused by the use of a fluid that causes excessive abrasion.

Furthermore, this warranty does not cover the rubber parts, or other parts that are subject to wear in normal operation, used in this product and its accessories.

### 4. Parts

Parts for this product will be kept available for 5 years after discontinuation of production. Once 5 years have elapsed after close of production, availability of parts for this product cannot be guaranteed.

Notes:

A large grid area for taking notes, consisting of approximately 25 columns and 35 rows of small squares. The grid is empty and occupies most of the page below the 'Notes:' label.

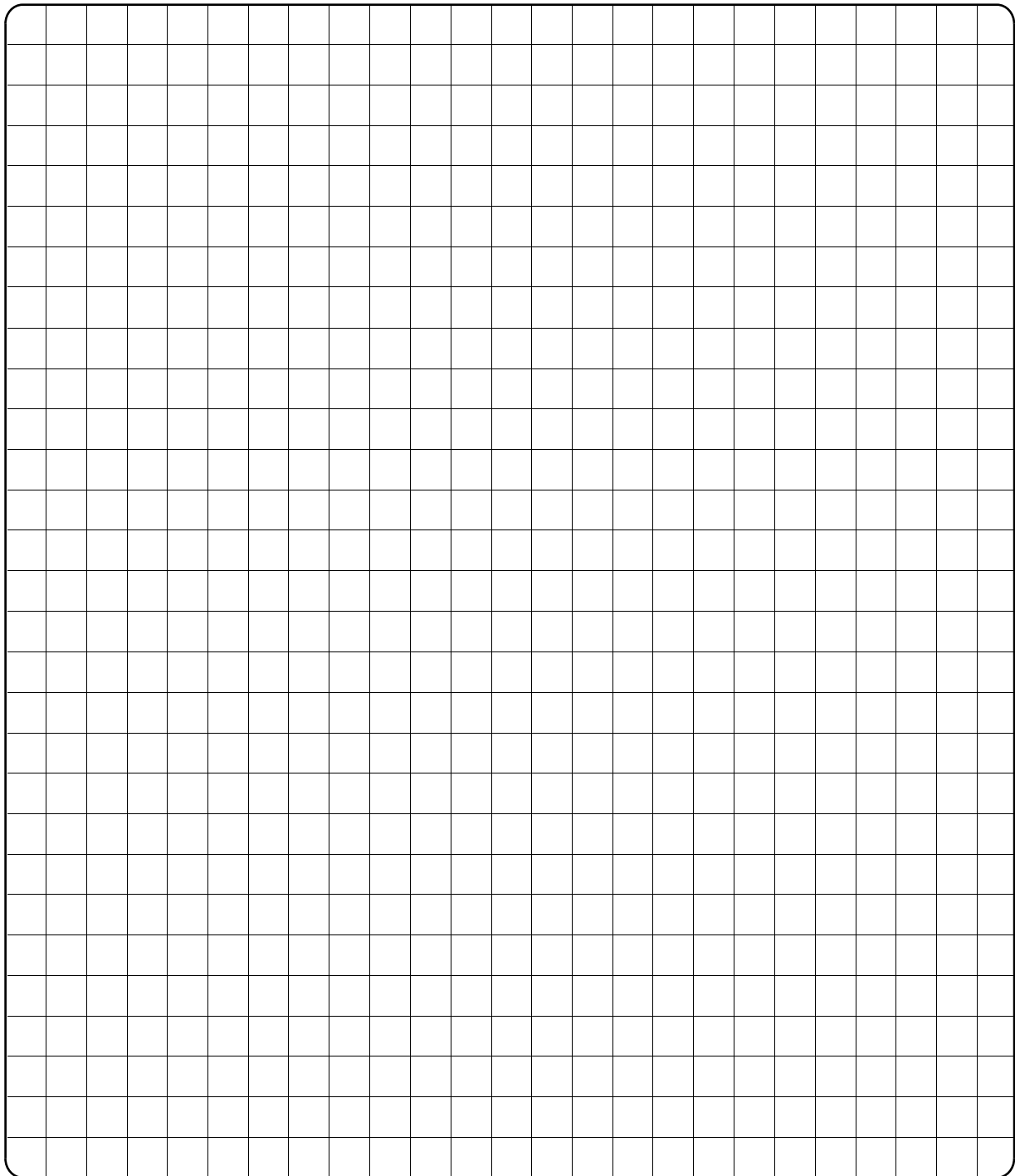

**DELLMECO**

Świerkowa 2  
83-330 Glinz  
POLAND  
Tel.: +48 532 220 722

[office@dellmeco.com](mailto:office@dellmeco.com)  
[www.dellmeco.com](http://www.dellmeco.com)

